



MGH GEARHEAD 1/3 HP (M-33) 1/2 HP (M-50)

installation/ maintenance

ELECTRIC DOOR OPERATOR

UNPACKING CHECK

If there is evidence of damage upon delivery of OPERATOR, file claim with Freight Carrier.

The following parts are furnished as standard, except on special orders.

1. Power Unit
2. Door Shaft Sprocket with Key
3. Chain and Connecting Link package
4. Control Station
5. Wiring Diagram in cover

FOREWORD TO OWNER

The M-33 is a worm gear reduced DOOR OPERATOR, designed to operate in either left or right hand, vertical or horizontal installations.

An adjustable CLUTCH ASSEMBLY is mounted on the REDUCER output shaft. When the CLUTCH is properly adjusted, DOOR OPERATOR protection is obtained by allowing the CLUTCH to slip if the door is obstructed, or if locks are not disengaged. By loosening the adjustment knob, the CLUTCH can be disengaged for manual operation.

Properly installed and maintained, your M-33 OPERATOR will provide many years of efficient, trouble free operation. Please observe these instructions carefully.

IMPORTANT NOTES PRIOR TO INSTALLATION

1. This OPERATOR will not efficiently operate a door which is damaged, improperly installed or maintained; is not designed to operate beyond its specified limitations and is not a substitute for weakened springs.
2. When installing the operator be sure to provide adequate space for easy service and maintenance.

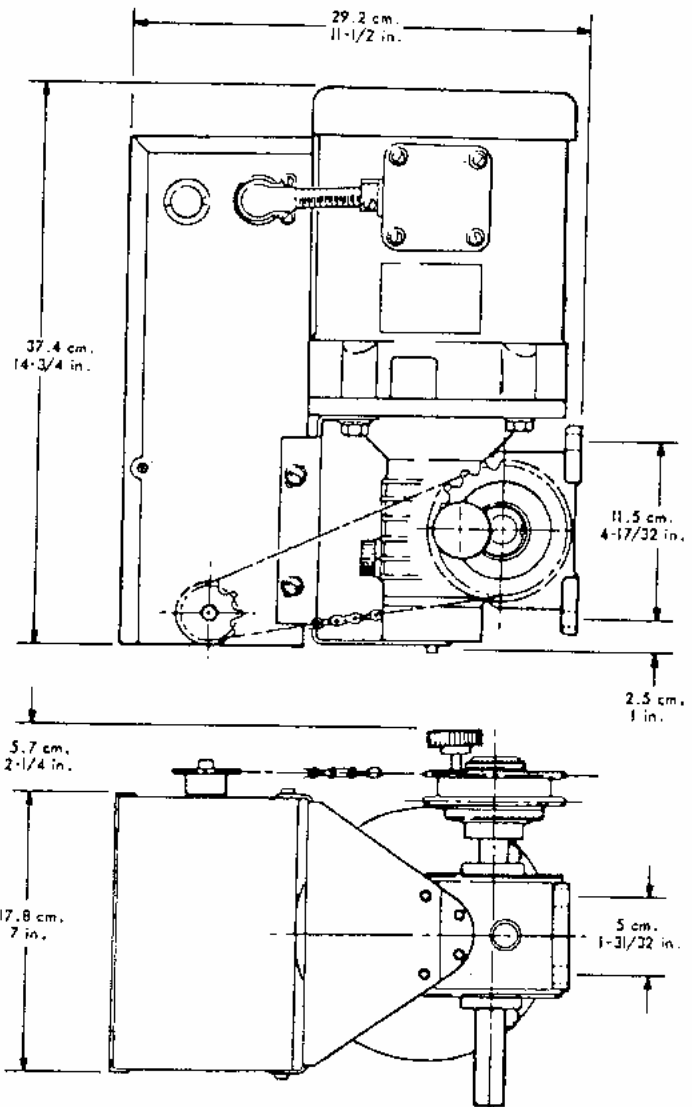

INSTALLATION

MECHANICAL INSTALLATION

1. Check that electrical power supply (voltage & phase) agrees with ratings on name plate.
2. Attach the CLUTCH ADJUSTMENT KNOB to the CLUTCH ASSEMBLY. Use of tool on KNOB will cause damage.
3. Check FLUID LEVEL in gear reducer.

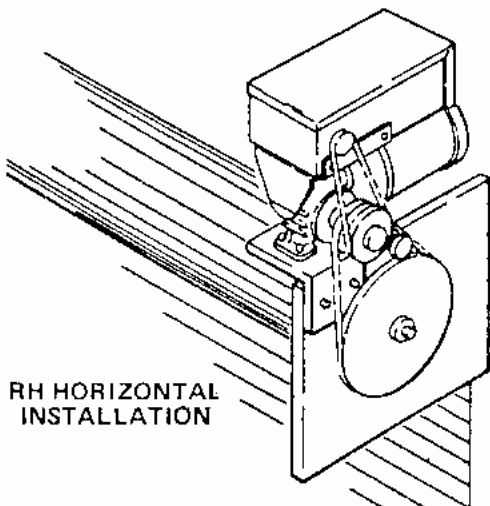
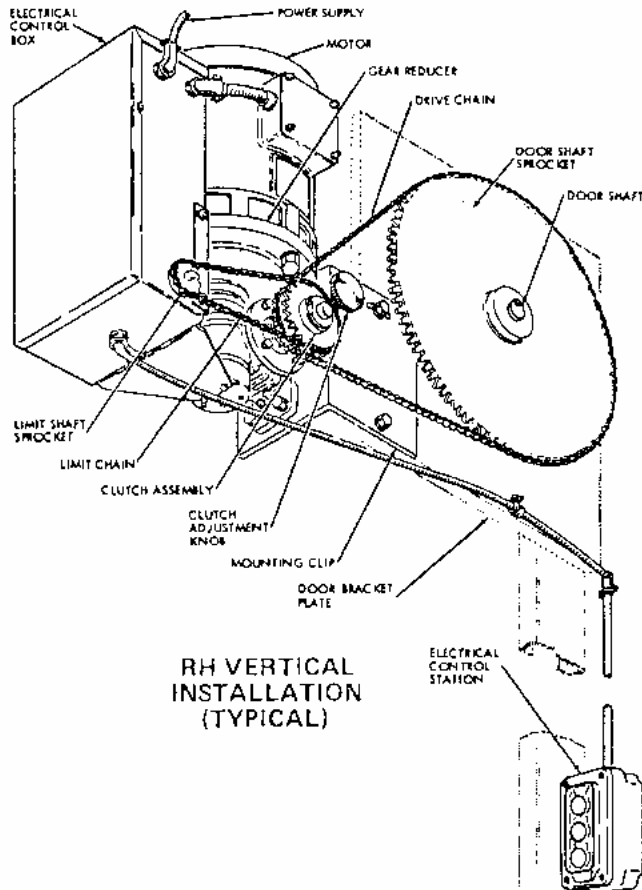

4. Check that (2) 7/16" holes for MOUNTING CLIP (supplied with door) are drilled in DOOR BRACKET PLATE. If missing, locate required (2) holes as shown.

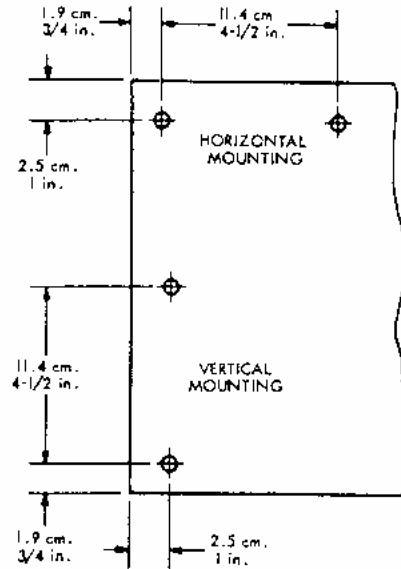

5. Attach MOUNTING CLIP to OPERATOR with (4) 5/16" x 1-3/4" bolts, lockwashers and nuts.
6. Install OPERATOR and Mounting Clip Assembly to Door Bracket Plate with (2) 3/8" x 1-3/4" bolts, lockwashers and nuts. **HAND TIGHTEN ONLY.**
7. Install DOOR SHAFT SPROCKET and key. Align with inboard sprocket of CLUTCH ASSEMBLY and tighten set screw.
If DOOR SHAFT does not have a keyway, align DOOR SHAFT SPROCKET with inboard sprocket of CLUTCH ASSEMBLY. Using set screw hole in sprocket hub, drill 5/16 dia hole thru DOOR SHAFT. Insert 5/16 rollpin and secure by inserting 3/16" rollpin inside 5/16" rollpin.
8. Install DRIVE CHAIN between DOOR SHAFT SPROCKET and CLUTCH ASSEMBLY inboard sprocket. Shorten CHAIN if necessary. Adjust tension as shown and tighten all bolts.

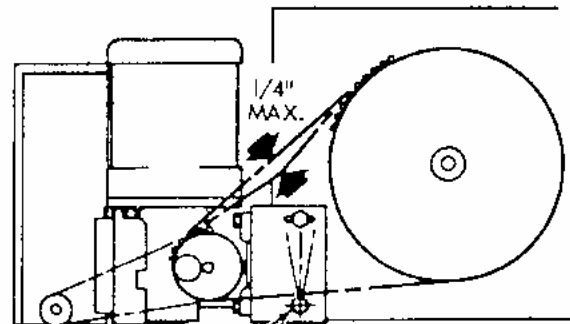

TIGHTEN PIVOT BOLT AFTER ADJUSTMENT

ELECTRICAL INSTALLATION

1. Electrical wiring shall be done by a licensed electrician per local electrical code.
2. See **INSTALLATION WIRING DIAGRAM** inside cover of **ELECTRICAL CONTROL BOX**.
3. Install **CONTROL STATION** and/or optional auxiliary control equipment, at a location where personnel will have a clear view of the door operation.
4. Connect incoming power source.

THIS UNIT MUST BE PROPERLY GROUNDED

- a. Connect ground lead to **GREEN SCREW** located in bottom of **ELECTRICAL CONTROL BOX**.
- b. If this **OPERATOR** has an Underwriters Laboratories (U/L) label, it will have either constant pressure push-button on **CLOSE**, or provision for the connection of a **DOOR PROTECTION EDGE** to reverse the door when it comes in contact with an obstruction.
The U/L label becomes void if any internal wiring changes are made which causes the **OPERATOR** (without a **DOOR PROTECTION EDGE**) to function with momentary push-button on **CLOSE**.

5. Check motor rotation with **CLUTCH** disengaged -- if **OPERATOR** rotates in wrong direction:

On three-phase unit: disconnect electrical power and reverse any two incoming leads.

On single-phase unit: disconnect electrical power and refer to **WIRING DIAGRAMS** located in cover of **ELECTRICAL CONTROL BOX**.

CLUTCH ADJUSTMENT

EXERCISE EXTREME CAUTION WITH CHAINS AND OTHER MOVING PARTS

AT THIS POINT LIMIT SWITCHES HAVE NOT BEEN SET, SO EXERCISE CAUTION, SO AS NOT TO DRIVE DOOR INTO UP-STOPS OR INTO FLOOR DURING CLUTCH ADJUSTMENT.

1. With door closed, tighten **CLUTCH ADJUSTMENT KNOB** 1/4 turn after resistance is felt.
2. Open door and check adjustment as follows:
If **CLUTCH** does not slip: Proceed to Step #3.
If **CLUTCH** slips: Stop operation and tighten **KNOB** 1/2 turn.
3. With door closed and slide bolts engaged, push **OPEN** pushbutton:
If **CLUTCH** slips. It is properly adjusted.
If **CLUTCH** does not slip: Stop operation and back off **KNOB** 1/4 turn.

LIMITS ADJUSTMENT

EXERCISE EXTREME CAUTION WITH CHAINS AND OTHER MOVING PARTS.

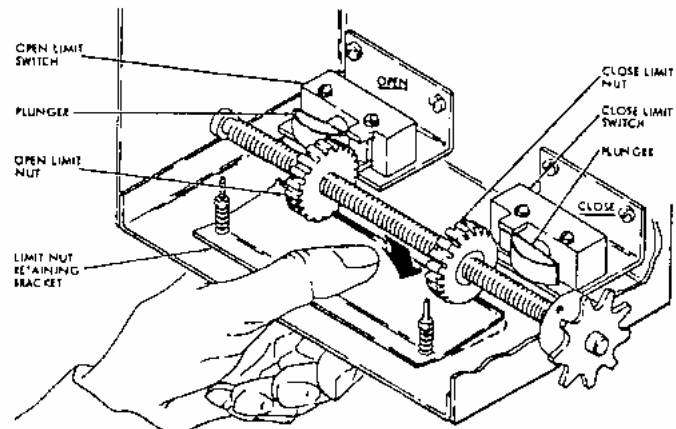

OPEN ADJUSTMENT

With slide bolts disengaged, push **OPEN** push-button to open door within 3" of **UP-STOPS**.

If door stops in mid-travel:

1. Disconnect electrical power.
2. Back-off **OPEN LIMIT NUT** a few turns.
3. Connect electrical power.
4. Push **OPEN** push-button and note door travel.
5. Repeat adjustment until door just touches **UP-STOPS**.

If door does not stop in mid-travel:

1. Stop door approximately 3" from **UP-STOPS**.
2. Disconnect electrical power.
3. Turn **OPEN LIMIT NUT** towards **OPEN LIMIT SWITCH** until **SWITCH** clicks, then back-off one full turn.
4. Connect electrical power.
5. Push **OPEN** push-button and note door travel.
6. Repeat adjustment until door just touches the **UP-STOPS**.

CLOSE ADJUSTMENT

Push **CLOSE** push-button to close door within 3" of floor.

1. Disconnect electrical power.
2. Turn **CLOSE LIMIT NUT** towards **CLOSE LIMIT SWITCH** until **SWITCH** clicks, then back-off one full turn.
3. Connect electrical power.
4. Push **CLOSE** push-button and note door travel.
5. Repeat adjustment until door touches floor.

FINAL CHECK:

TIGHTEN ALL MOUNTING BOLTS AND SPROCKET SET SCREWS.

REPLACE COVER OF ELECTRICAL CONTROL BOX.

PARTS

When ordering, state model number, part number and part description.

DOOR OPERATOR ASSEMBLY, M-33

1	20-20	MOTOR, 115V/230V ac., 1/3 hp. single phase
	20-29	MOTOR, 230V/460V ac., 1/3 hp. three phase, alternate
2	80-76-5	(2) BOLT, 3/8 - 16 x 1
	80-181	(2) WASHER, Lock
3	80-76-6	(2) BOLT, 3/8 - 16 x 1-1/4
	80-181	(2) WASHER, Lock
	80-168	(2) WASHER, Flat
4	71-100421	CLUTCH ASSEMBLY, DOOR OPERATOR,
5	80-129-3	SET SCREW
6	80-534-4	KEY
7	19-48046	CHAIN, Limit, No. 48
8	10-3435	Bracket, Electrical Control Box
9	80-900	(2) SCREW, M5 x 40 mm.
	80-178	(2) WASHER, Lock, No. 10
	80-7013	(2) WASHER, Flat, No. 10
10		ELECTRICAL CONTROL BOX ASSEMBLY
11	80-377-7	(4) SCREW, Pan Head, 10-32 x 1/2
	80-197	(4) WASHER, Lock, No. 10
12	27-501	CABLE, Electrical Control Box
13	27-2020	(2) CONNECTOR, 90°
14	32-30	GEAR REDUCER,

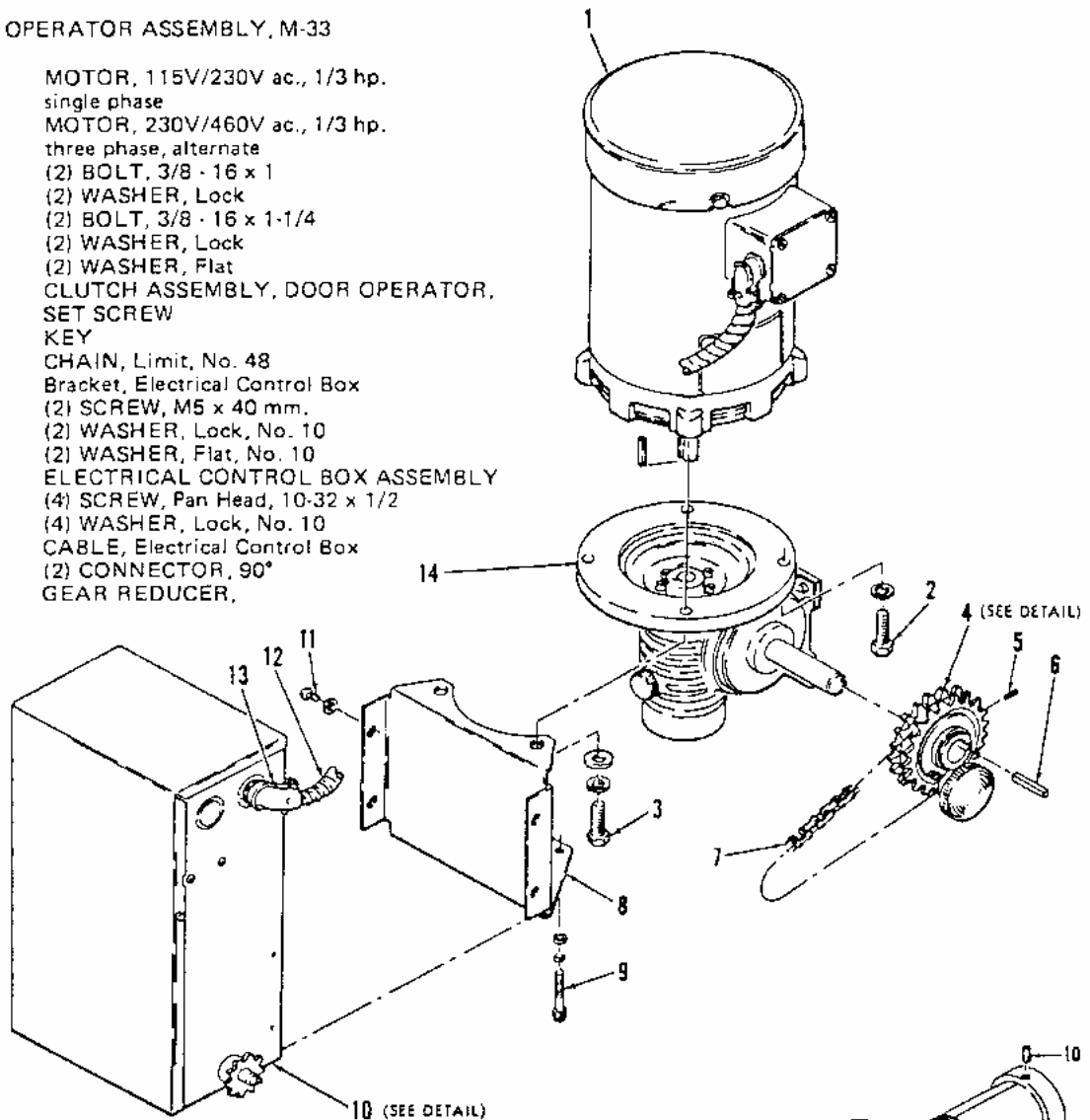

71-100421 CLUTCH ASSEMBLY

1	41-333	KNOB
2	80-412	RING, Lock
3	12-1003	(2) BUSHING
4	10-3433	DISC, Locking
5	10-3434	(2) PLATE, Friction
6	39-333	(2) DISC, Friction
7	15-100421	SPROCKET, Double
8	80-160	WASHER, Spring
9	12-33	HUB
10	80-129-3	SET SCREW

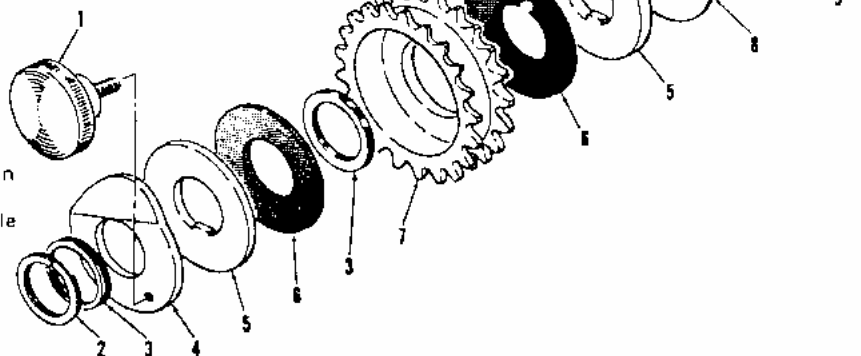

CONTROL BOX

No.	Part No.	Description	Req'd
1	15-482094	SPROCKET, 48B9 3/8" Bore	1
2	80-201-2	SPACER, 3/8" x 3/4" x 3/64"	1
3	11-5050	SHAFT, Limit	1
4	31-173	NUT, Limit 1/2"	2
5	27-2045	CONNECTOR, Bx 45°	1
6	12-683	BEARING, 3/8"	2
7	80-201-2	SPACER, 3/8" x 3/4" x 3/64"	AR
	80-201-1	SPACER, 3/8" x 3/4" x 3/32"	AR
8	80-351	RETAINER, 3/8"	1
9	80-340-9	PIN, Roll 1/8" x 1"	1
10	80-176	LOCKWASHER, # 6	4
11	80-216	NUT, Hex #6-32	4
12	80-1-12	SCREW, # 6-32 x 1"	2
13	10-5076	BOX, Control	1
14	80-2-6	SCREW, #8-32 x 1/2"	2
15	80-1001	NUT, Tinnerman	2
*16	21-5115	TRANSFORMER, 115/241 Volt	1
	21-5230	TRANSFORMER, 208 - 230/24 Volt	
	21-5460	TRANSFORMER, 460/24 Volt	
	21-5575	TRANSFORMER, 550 - 575/24 Volt	
17	80-1-15	SCREW, #6-32 x 1 1/2"	4
*18	23-2015	SWITCH, Limit DPDT (No. req'd varies with wiring)	2
	23-2016	SWITCH, Limit SPST	
	23-20	SWITCH, Limit SPDT	
19	80-446	WASHER, Flat # 6	4
20	31-113	SPACER	4
21	10-5022	PLATE, Limit Depression	1
22	80-294	NUT, Lock #6-32	2
23	18-5043	SPRING	2
*24	24-74	RELAY, I.R. 230 Volt Opt.	1
	24-79	RELAY, I.R. 115 Volt Opt.	
25	27-69910	TERMINAL, Board 10 Lug	1
26	80-8625	SCREW, Tap #8-32 x 5/8"	4
*27	25-2006	OVERLOAD, 6 AMP. (Single Phase)	1
	25-2008	OVERLOAD, 8 AMP. (Single Phase)	
	25-2010	OVERLOAD, 10 AMP. (Single Phase)	
	25-2012	OVERLOAD, 12 AMP. (Single Phase)	
	25-2015	OVERLOAD, 15 AMP. (Single Phase)	
	25-2017	OVERLOAD, 17 AMP. (Single Phase)	
	25-8002-5	OVERLOAD, Adjustable 1-6-2.5 AMP. (Three Phase)	
	25-8004	OVERLOAD, Adjustable 2.5 - 4.0 AMP. (Three Phase)	
	25-8006	OVERLOAD, Adjustable 4.0 - 6.0 AMP. (Three Phase)	
28	10-5021	COVER, Box	1
29	80-8250	SCREW, Tap #8-32 x 1/4"	2
30	03-8024	CONTROLLER, Reversing 24 Bolt Control Circuit	1
31	10-132	BRACKET, Double	AR
32	10-5074	BRACKET, Single	AR
33	24-77	RELAY, R. 1. 24 Volt	AR
34	80-7002	SCREW, 8/32" x 3/8" Self Tapping	AR

*USE PART NUMBER AND DESCRIPTION COMMON TO YOUR OPERATOR.

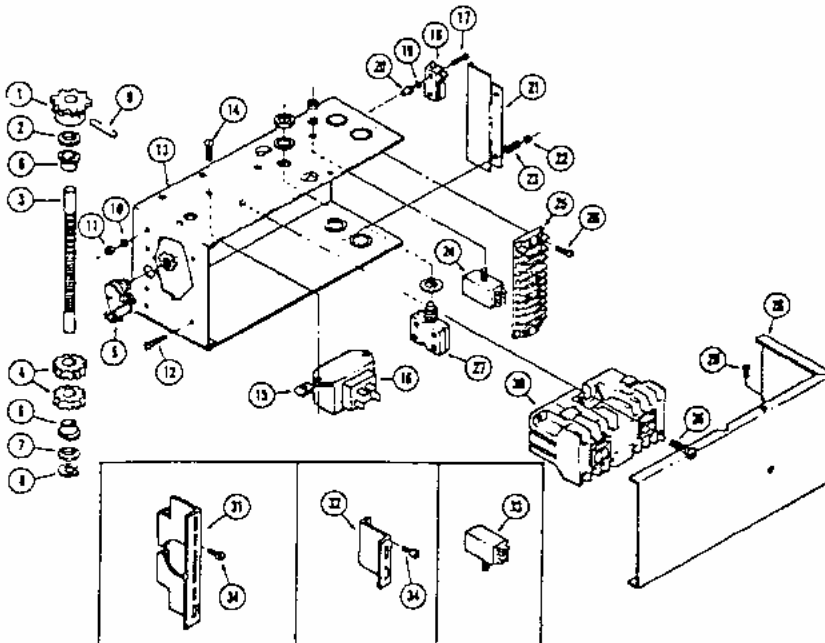

MAINTENANCE

Preventive Maintenance is the best way to avoid unnecessary expense and inconvenience, and to insure trouble free operation. Have a qualified serviceman inspect your operator approximately 6 months after installation and have him recommend a maintenance schedule according to your Operators usage.

PERIODIC MAINTENANCE

LIMIT AND DRIVE CHAINS

Lubricate with S.A.E. 30 oil.

Adjust limit chain by loosening (4) mounting screws and adjust Electrical Control Box to remove slack.

Adjust Drive Chain, as shown in Step 8, Page 2.

GEAR REDUCER

Gear Reducer is installed with 0.2 liters (6-3/4 fl. oz.) S.A.E. 40 gear oil for operating temperatures 4°C (40°F) to 38°C (100°F)

For prolonged use in other operating temperatures, it is recommended that the following gear oil grades be used.

38°C (100°F)	to	65°C (150°F)	S.A.E. 50
4°C (40°F)	to	38°C (100°F)	S.A.E. 40
-18°C (0°F)	to	4°C (40°F)	S.A.E. 20
-40°C (-40°F)	to	-18°C (0°F)	S.A.E. 10

Under normal use it is recommended that the gear oil be changed every two years. With more severe use, consult your Serviceman for recommended change schedules.

CLUTCH

Follow adjustment procedures on Page 3. If clutch cannot be adjusted, replace friction discs.

PROBLEMS

If a problem occurs, follow these simple checks before calling the Serviceman:

OPERATOR DOES NOT RUN WHEN BUTTON IS PRESSED.

1. Check for blown fuses or tripped circuit breakers.
2. Check for tripped Overload Protector, on Operator.

CAUTION: Do not tamper with electrical controls --- call your Serviceman.

OPERATOR FAILS TO SHUT OFF AT FULLY OPEN OR CLOSED POSITION.

1. Check Limit adjustment
2. Check for broken Limit Chain or inoperative Limit Shaft.

LIMIT SWITCHES DO NOT HOLD SETTINGS.

1. Check for loose Limit Chain. Loosen (4) mounting screws and adjust Electrical Control Box to remove slack.
2. Check for worn or loose Limit Shaft.
3. Check to be sure Retaining Bracket is in notch in each Limit Nut.

MOTOR RUNS AND CLUTCH SLIPS.

1. Check for jammed or obstructed door.
2. Check Clutch adjustment. If it can no longer be adjusted, replace friction discs.

NOTE TO INSTALLER:

RECORD THE FOLLOWING INFORMATION FOR FUTURE REFERENCE:

MODEL # _____ SERIAL # _____

PLEASE LEAVE THIS MANUAL AND WIRING DIAGRAM WITH OWNER.



cp Allstar Corporation
PO Box 240
Downingtown, PA 19335

Manual #105580
Revision A
February 1, 2000