

SLIDE GATE OPERATORS

SL Series

SLC COMMERCIAL

- 1/2 or 1 HP continuous-duty PSC motor
- 115 VAC or 230 VAC single phase

SLD COMMERCIAL/RESIDENTIAL

- DC-powered battery back-up with advanced soft start/ soft stop motor control
- Full-time 1/2 HP DC motor
- Selectable fail-safe or fail-secure modes of operation
- Solar power capable

SLR RESIDENTIAL

- 1/2 HP PSC motor
- 115 VAC or 230 VAC single phase

COMMON FEATURES

- Black UV Stabilized polyethylene cover
- Reliable chain drive
- Pad mount standard; post mount optional
- Exterior reset button
- UL325/UL991 compliant APeX controller
- Manual disconnect
- Fully integrated radio receiver

Linear[®]

Building On Innovation.



All Models ETL Listed;
UL325 Compliant



Supporters and Proud Members of



ELECTRICAL

- Integral entrapment sensing system with digital set point for quick accurate adjustment and enhanced safety
- Continuous-tone entrapment alarm with reset button
- Integrated programmable warning beeper during gate movement
- LED diagnostic display for ease of setup and troubleshooting
- Selectable pre-start alarm with provision for ADA compliant vis pre-start and run alarm
- Regulated 24 Volt DC power available for access control accessories
- Integrated maximum run and auto close timer (0-9 minutes)
- Built-in networked dual gate capability using 3-wire shielded cable

MECHANICAL

- Heavy-duty, zinc-plated, steel chassis
- Easy-to-operate emergency manual disconnect handle
- 1/2 HP #41 chain, 1 HP #40 chain - 31' included
- Universal pad mount standard; optional post mount kit

SL SERIES SLIDE GATE OPERATOR SPECIFICATIONS

Model	HP	Voltage (Single Phase)	Drive Type	Maximum Gate Length	Maximum Gate Weight	Gate Speed	Maximum Cycles	
SLC	SLC-2	1 / 2	115 or 230 V	#41 chain	37'	1000 lbs	11"/sec	continuous duty
	SLC-1	1	115 or 230 V	#40 chain	45'	2000 lbs	11"/sec	continuous duty
SLD	SLD-211	1/2	115V 24 VDC battery backup (solar charger optional)	#41 chain	40'	1000 lbs	12"/sec	continuous duty
SLR	SLR-211	1/2	115 V	#41 chain	25'	500 lbs	11"/sec	150/day
	SLR-221	1/2	230 V	#41 chain	25'	500 lbs	11"/sec	150/day

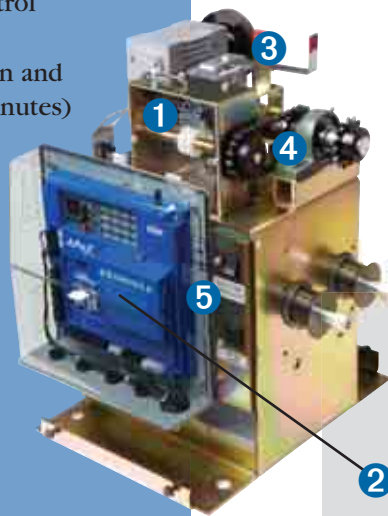

1 Rotary Mechanical Limits

Easy access inside control box

2 APeX Controls

- UL325/UL991 compliant 24 VDC control module
- Full featured for access control, security, and entrapment protection

3 Manual Disconnect

- Simple and secure manual operation during power failure or emergency
- Optional remote cable kit for outside-the-gate access

4 Heavy-Duty Components

Gear reducer and pillow block bearing for smooth, reliable, quiet power transmission

5 Standard Convenience Features

- Exterior reset button
- Power on/off button
- Accessory power outlet on 115 V machines
- Integrated 3-button station

- Includes APeX Controller with integrated radio receiver, plug-in loop detector capability, surge protection, and easy to read labeling standard.

Dimensions

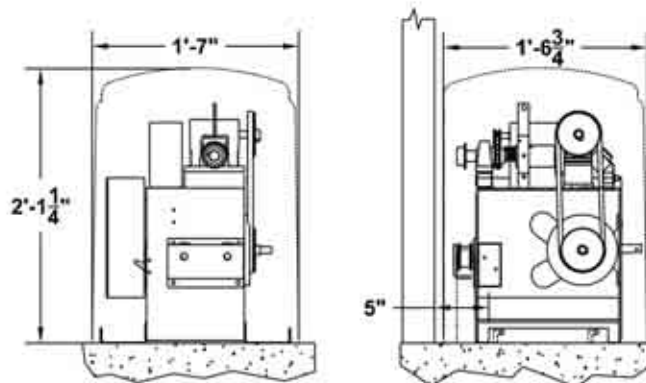

CAUTIONS



- Automatic gates not for pedestrians
- Automatic gate operators designed for vehicular traffic only; operators are powerful and can cause serious injury or death; DIRECT ALL PEDESTRIAN TRAFFIC TO SEPARATE PEDESTRIAN GATE
- UL325 requires use of contact or non-contact anti-entrapment devices
- ASTM F2200 requires that all exposed rollers are covered

Linear[®]
Building On Innovation.

(800) 421-1587 • www.linearcorp.com